

Manufacturer / Fabricant

Customer / Client

VEM motors GmbH - Werk Wernigerode
Carl-Friedrich-Gauß-Straße 1

38855 WERNIGERODE
Deutschland

Three-phase motors with squirrel cage rotor, standard motors
 Housing grey cast iron / *Moteurs triphasés à cage, moteurs standards fonte grise*

IE3-Y43R 160 M4 NS LL HW

Mounting position /
Position de montage



Type of mounting: / *Forme de construction:* IM V1
 Flange: / *Bride:* FF 300[A 350]
 Position of terminal box / *Position de la boîte à bornes*
 : on the top / *sur le dessus*

Terminal box / *Boîte à bornes:* KK 63/25 A
 Cable gland / *Presse-étoupe O:*
 2 x Sealing plug M 40x1,5 / *2 x Bouchon M 40x1,5*

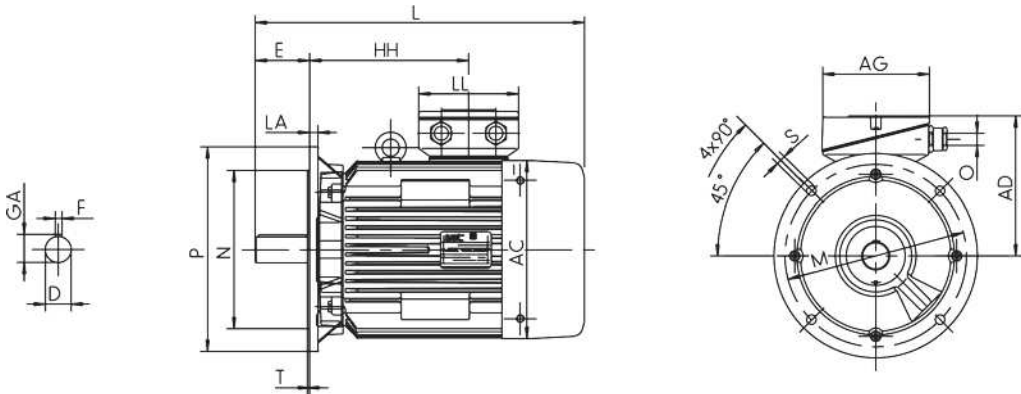

Motor / Moteur

A	AA	AB	AC	AD	B	B'	BA	BA'	BB	C	CA	K	K'
-	-	-	258	214	-	-	-	-	-	-	-	-	-

L	LC	H	HA	HD	HH	BI
609	-	160	-	-	329	40

Terminal box / Boîte de connexion

AG	LL	BE	AH
193	167	-	-

Flange / bride

P	N	LA	M	T	S
350	250	13	300	5	18

Tolerances / Tolérances

H	N	D	DA
-0,5	h6	k6	k6

Shaft-DS / arbre-DS

D	E	GA	F	DB
42	110	45	12	DIN 332 DS- M16

Shaft-NS / arbre-NS

DA	EA	GC	FA
-	-	-	-

DB...Centre hole / Orifice de centrage

Delivery conditions and/or official regulations: / *Conditions de livraison et/ou instructions officielles* IEC / EN 60034-1

This document was produced electronically, all specifications are valid only after confirmation of the manufacturer / *Document électronique, données valides uniquement après confirmation par le constructeur*