

Dimensional sheet / Dimensions



18.05.2021 MADE WITH VEM EKAT V10.9 / ELABORÉ AVEC LE CATALOGUE VEM EKAT V10.9

Manufacturer / Fabricant

Customer / Client

VEM motors GmbH - Werk Wernigerode
Carl-Friedrich-Gauß-Straße 1

38855 WERNIGERODE
Deutschland

Three-phase motors with squirrel cage rotor,
 Housing grey cast iron / Moteurs triphasés à cage, fonte grise

IE3-W43R 315 M4 HW

Mounting position /
Position de montage

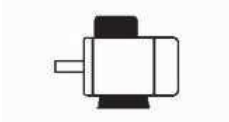

Type of mounting: / *Forme de construction:* IM B3
 Flange: / *Bride:* -
 Position of terminal box / *Position de la boîte à bornes*
 : on the top / *sur le dessus*
 Brake type: / *Frein:*
 Forced-ventilation: / *Ventilation forcée*

Terminal box / *Boîte à bornes:* KK 200 A
 Cable gland / *Presse-étoupe* O: 1 x Sealing plug / *Bouchon*

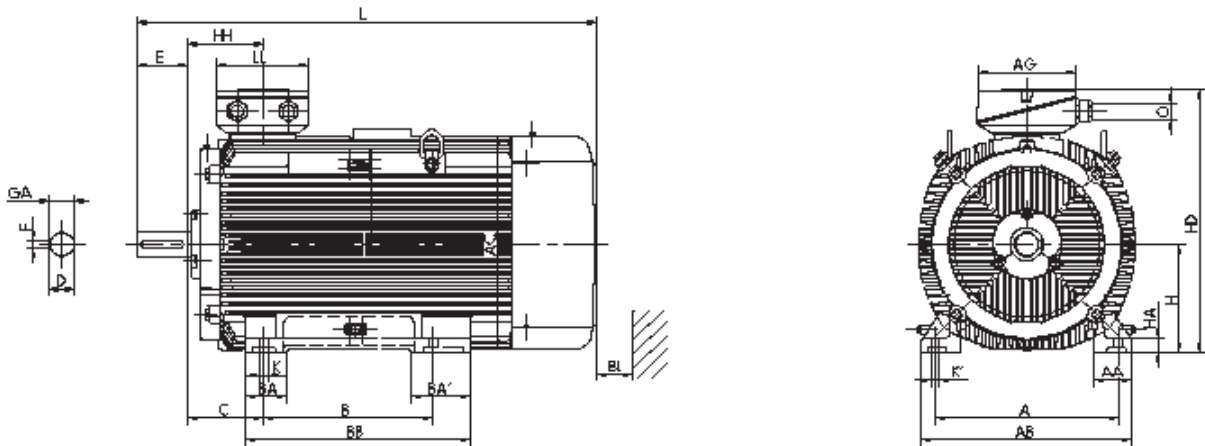

Motor / Moteur

A	AA	AB	AC	AD	B	B'	BA	BA'	BB	C	CA	K	K'
508	126	590	550	-	457		120	150	554	216	-	28	35

de connexion

L	LC	H	HA	HD	HH	BI	L	AG	LL	BE	AH
1135	-	315	44	731	211	100	-	282	242	-	-

Flange / bride

P / P	N	LA	M	T	S	Tolerances / Tolérances					
-	-	-	-	-	-	H	N	D	DA		
						-1	h6	m6	m6		

Shaft-DS / arbre-DS

D	E	GA	F	DB	DA	EA	GC	FA
80	170	85	22	DIN 332 DS- M20	-	-	-	-

Shaft-NS / arbre-NS

DB...Centre hole / Orifice de centrage

Delivery conditions and/or official regulations: / *Conditions de livraison et/ou instructions officielles* IEC / EN 60034-1

This document was produced electronically, all specifications are valid only after confirmation of the manufacturer / *Document électronique, données valides uniquement après confirmation par le constructeur*