



Manufacturer

Customer

VEM motors GmbH - Werk Zwickau
Äußere Dresdner Str. 35

08066 ZWICKAU
Deutschland

Three-phase motors with squirrel cage rotor, standard motors, pole-changing, two speeds for squarely increasing loading torque

Type	K21R 90 L 8-4L		
Number of poles	[-]	8	4
Design output	(kW)	0,37	1,5
Duty type		S1	
Efficiency determination	[-]	EN 60034-2	
Design frequency	(Hz)	50	
Design speed	[rpm]	690	1400
Design voltage	(V)	400	
Connection	[-]	Y/YY	
Design current	[A]	1.33	3.70
Relative pull-in current	[-]	2,6	1,6
Relative starting torque	[-]	1,2	1,7
Relative pull-up torque	[-]	1,2	1,7
Relative pull-out torque	[-]	1,4	1,9
Power factor	[-]	0,64	0,84
Efficiency	[%]	63	70
Th. cl.		155(F)	
Coolant temperature	(°C)	-20°C...+40°C	
Altitude above sea level	(m)	1000m	
Degree of protection IP		IP55	
Moment of inertia	(kgm ²)	0,00375	
Motor weight	(kg)	18	
Bearing, D-side		6205 2Z C3	
Bearing, N-side		6205 2Z C3	
Relubrication interval	(h)		
Grease type		Asonic GLY 32	
Grease amount	(g)		

Options

Type of mounting	IM B3
Flange	-
Terminal box	Standard
Position of terminal box	on the top
Cable gland	Sealing plug
Position of cable entry	right
Shaft	Standard, 1 shaftend
Bearing	Easy bearing arrangement
Limit values to vibration velocity	Class A
	Balancing with half key
Colour system	01 Moderate (KK C2),RAL 7031 blue-grey
Delivery conditions and/or official regulations:	IEC / EN 60034-1

This document was produced electronically, all specifications are valid only after confirmation of the manufacturer

Three-phase motors with squirrel cage rotor, standard motors, pole-changing, two speeds for squarely increasing loading torque

K21R 90 L 8-4L

Mounting position

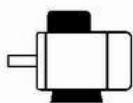

Type of mounting: IM B3
 Flange: -
 Position of terminal box: on the top
 Brake type:
 Forced-ventilation:

Terminal box: KA 05
 Cable gland O: 2 xSealing plug

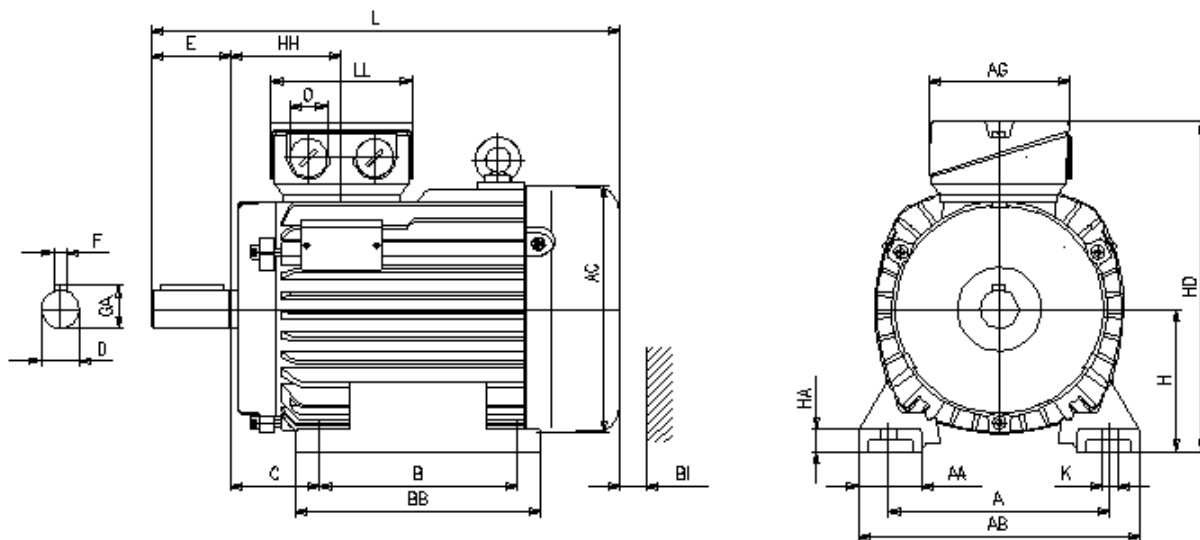

Motor

A	AA	AB	AC	AD	B	B'	BA	BA'	BB	C	CA	K	K'		
140	40	178	157	-	125	125	-	-	155	56	-	10	10		
												Protection cover		Terminal box	
L	LC	H	HA	HD	HH	BI	L	AG	LL	BE	AH	-	-		
297	-	90	14	210	70	16	-	92	92	-	-	-	-		

Flange

P	N	LA	M	T	S								
-	-	-	-	-	-								

Tolerances

H	N	D	DA
-0,5	j6	k6	k6

Shaft-DS

D	E	GA	F	DB
24	50	27	8	DIN 332 - DS M8

Shaft-NS

DA	EA	GC	FA
-	-	-	-

DB...Centre hole

Delivery conditions and/or official regulations: IEC / EN 60034-1

This document was produced electronically, all specifications are valid only after confirmation of the manufacturer