



Manufacturer

Customer

VEM motors GmbH - Werk Wernigerode
Carl-Friedrich-Gauß-Straße 1

38855 WERNIGERODE
Deutschland

Three-phase motors with squirrel cage rotor,
Housing grey cast iron

Type	IE3-W43R 315 MY4	TPM NS VL HW	
Design output	(kW)	200	
Design torque	(Nm)	1286	
Class IE	[-]	IE3-96%	
Efficiency determination		EN 60034-2-1	
Duty type		S1	
Design frequency	(Hz)	50	
Design speed	[rpm]	1485	
Voltage	(V)	400/690	
Connection	[-]	D	Y
Current	[A]	367.0	212.8
Relative pull-in current	[-]	8,3	
Relative starting torque	[-]	1,8	
Relative pull-up torque	[-]	1,8	
Relative pull-out torque	[-]	2,4	
Efficiency100/75/50 %	[%]		96 / 96,2 / 95,9
Power factor	[-]	0,82	
Th. cl.		155(F/B)	
Coolant temperature	(°C)	-20°C...+40°C	
Altitude above sea level	(m)	1000m	
Degree of protection IP		IP55	
Moment of inertia	(kgm ²)	2,73	
Motor weight	(kg)	970	
Bearing, D-side		NU 317 E	
Bearing, N-side		6316 C3	
Relubrication interval	(h)	4000	
Grease type		ASONIC GHY 72	
Grease amount	[cm ³]	57/52	
A-sound pressure level	(dB)	70	

Options

Type of mounting	IM B3
Flange	-
Terminal box	Standard
Position of terminal box	on the top
Cable gland	Sealing plug
Position of cable entry	right
Shaft	Standard, 1 shaft end
Bearing	Relubrication device, heavy bearing arrangement
Special details to bearings	Fixed bearing, N-side
Winding protection	1 set ptc resistors
Limit values to vibration velocity	Class A
Colour system	Balancing with half key
Delivery conditions and/or official regulations:	01 Moderate (KK C2),RAL 7031 blue-grey IEC / EN 60034-1

This document was produced electronically, all specifications are valid only after confirmation of the manufacturer

Data sheet

07.07.2022 MADE WITH VEM EKAT 2022



Three-phase motors with squirrel cage rotor,
Housing grey cast iron

IE3-W43R 315 MY4 TPM NS VL HW

Mounting position

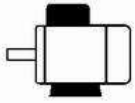

Type of mounting: IM B3
Flange: -
Position of terminal box: on the top
Brake type:
Forced-ventilation:

Terminal box: KK 400 A
Cable gland O: 1 xSealing plug

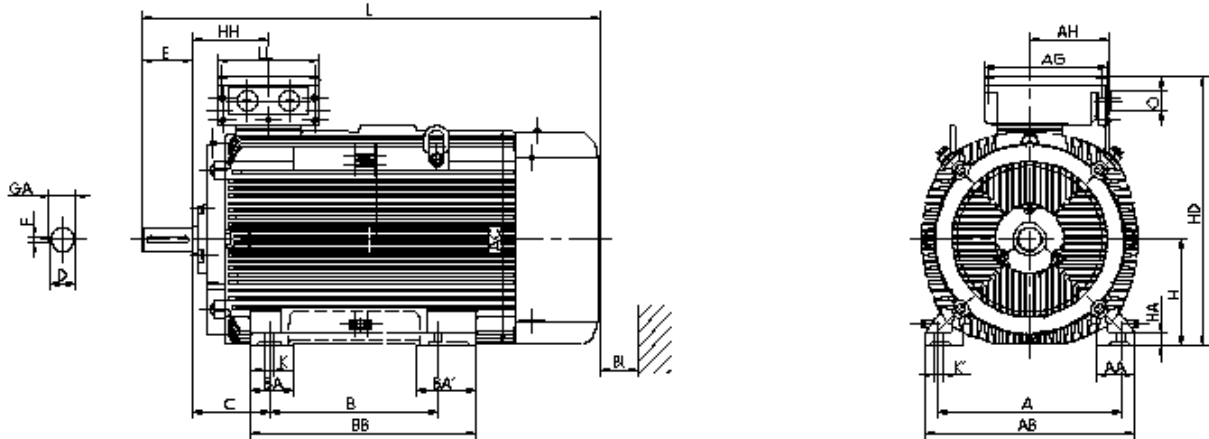

Motor

A	AA	AB	AC	AD	B	B'	BA	BA'	BB	C	CA	K	K'		
508	126	590	550	-	457		120	150	554	216	-	28	35		
												Protection cover		Terminal box	
L	LC	H	HA	HD	HH	BI		L	AG	LL	BE	BE	AH		
1210	-	315	44	768	211	100		-	315	294	-	-	-		

Flange

P	N	LA	M	T	S								
-	-	-	-	-	-								

Tolerances

H	N	D	DA
-1	h6	m6	m6

Shaft-DS

D	E	GA	F	DB
80	170	85	22	DIN 332 DS- M20

Shaft-NS

DA	EA	GC	FA
-	-	-	-

DB...Centre hole

Delivery conditions and/or official regulations: IEC / EN 60034-1

This document was produced electronically, all specifications are valid only after confirmation of the manufacturer