

Data sheet for three-phase Squirrel-Cage-Motors SIMOTICS

Data sheet for three-phase Squirrel-Cage-Motors

Motor type / Motor type : 1CV3131A

SIMOTICS SD - 132 S - IM B3 - 2p

Client order no. / Client order no.	Item-No. / Item-No.	Offer no. / Offer no.
Order no. / Order no.	Consignment no. / Consignment no.	Project / Project

Remarks / Remarks

Electrical data / Electrical data

Safe Area

U	Δ / Y	f	P	P	I	n	M	$\eta^{3)}$			$\cos\phi^{3)}$			I_A/I_N	M_A/M_N	M_K/M_N	IE-CL
[V]		[Hz]	[kW]	[hp]	[A]	[1/min]	[Nm]	4/4	3/4	2/4	4/4	3/4	2/4	I_f/I_N	T_f/T_N	T_B/T_N	
DOL duty (S1) / DOL duty (S1) - 155(F) to 130(B)																	
230	Δ	50	7.50	-/-	22.50	2950	24.5	90.1	91.0	91.0	0.92	0.90	0.84	8.3	1.9	3.9	IE3
400	Y	50	7.50	-/-	13.10	2950	24.5	90.1	91.0	91.0	0.92	0.90	0.84	8.3	1.9	3.9	IE3
460	Y	60	8.60	-/-	13.00	3550	23.0	90.2	90.8	90.5	0.92	0.90	0.84	8.2	2.0	3.9	IE3
460	Y	60	7.50	-/-	11.50	3560	20.0	90.2	90.4	89.6	0.91	0.88	0.82	9.4	2.2	4.5	IE3
IM B3 / IM 1001			FS 132 S			IP56	UKCA	IEC/EN 60034			IEC, DIN, ISO, VDE, EN						

Environmental conditions / Environmental conditions : -20 °C - +40 °C / 1,000 m Locked rotor time (hot / cold) / Locked rotor time (hot / cold) : 9.3 s | 13.6 s

Mechanical data / Mechanical data

Sound level (SPL / SWL) at 50Hz 60Hz Sound level (SPL / SWL) at 50Hz 60Hz	68 / 80 dB(A) ^{2) 3)}	72 / 84 dB(A) ^{2) 3)}	Thermal class Thermal class	F F
Moment of inertia Moment of inertia	0.0310 kg m ²		Duty type Duty type	S1
Bearing DE NDE Bearing DE NDE	6308 2Z C3	6308 2Z C3	Direction of rotation Direction of rotation	bidirectional bidirectional
bearing lifetime / bearing lifetime			Frame material Frame material	cast iron cast iron
$L_{10mh} F_{Rad min}$ for coupling operation 50 60Hz ¹⁾	40000 h	32000 h	Net weight of the motor (IM B3) Net weight of the motor (IM B3)	73 kg
$L_{10mh} F_{Rad min}$ for coupling operation 50 60Hz ¹⁾			Coating (paint finish) Coating (paint finish)	Special paint finish, resistant to salt-laden air C4 Special paint finish, resistant to salt-laden air C4
Regreasing device Regreasing device	Without Without		Color, paint shade Color, paint shade	RAL5010
Grease nipple Grease nipple	-/-		Motor protection Motor protection	(B) 3 PTC thermistors - for tripping (standard) (2 terminals) (B) 3 PTC thermistors - for tripping (standard) (2 terminals)
Type of bearing Type of bearing	Preloaded bearing DE Preloaded bearing DE		Method of cooling Method of cooling	IC411 - self ventilated, surface cooled IC411 - self ventilated, surface cooled
Condensate drainage holes Condensate drainage holes	With (standard) With (standard)			
External earthing terminal External earthing terminal	With (standard) With (standard)			
Vibration severity grade Vibration severity grade	A A			

Terminal box / Terminal box

Terminal box position Terminal box position	top top	Max. cross-sectional area Max. cross-sectional area	6 mm ²
Material of terminal box Material of terminal box	cast iron cast iron	Cable diameter from ... to ... Cable diameter from ... to ...	11 mm - 21 mm
Type of terminal box Type of terminal box	TB1 J01	Cable entry Cable entry	2xM32x1,5-1xM16x1,5
Contact screw thread Contact screw thread	M4	Cable gland Cable gland	3 plugs 3 plugs

Notes:
 I_A/I_N = locked rotor current / current nominal ¹⁾ L10mh according to DIN ISO 281 10/2010 ³⁾ Value is valid only for DOL operation with motor design IC411
 M_A/M_N = locked rotor torque / torque nominal ²⁾ at rated power / at full load
 M_K/M_N = break down torque / nominal torque

responsible dep. DI MC LVM	technical reference	created by DT Configurator	approved by	Technical data are subject to change! There may be discrepancies between calculated and rating plate values.	Link documents
SIEMENS	document type datasheet	document status released		document number	
	title 1LE1603-1CA12-2AB4-Z C02+H07+H22+R50+S03+Y53	rev. 943	creation date 2023-04-13		
© Siemens AG 2023					

Data sheet for three-phase Squirrel-Cage-Motors SIMOTICS

Data sheet for three-phase Squirrel-Cage-Motors

Motor type / Motor type : 1CV3131A

SIMOTICS SD - 132 S - IM B3 - 2p

Special design / Special design

C02	VIK version VIK version	R50	Larger terminal box Larger terminal box
H07	Stainless steel screws and bolts (outside the motor) Stainless steel screws and bolts (outside the motor)	S03	Special paint finish in sea air resistant C4 Special paint finish in sea air resistant C4
H22	IP 56 degree of protection IP 56 degree of protection	Y53	Paint finish in other standard RAL colours RAL5010 Paint finish in other standard RAL colours RAL5010

Notes:

responsible dep. DI MC LVM	technical reference	created by DT Configurator	approved by	<i>Technical data are subject to change! There may be discrepancies between calculated and rating plate values.</i>	Link documents
	document type datasheet	document status released		document number	
	title 1LE1603-1CA12-2AB4-Z	rev. 943	creation date 2023-04-13		
© Siemens AG 2023	C02+H07+H22+R50+S03+Y53				

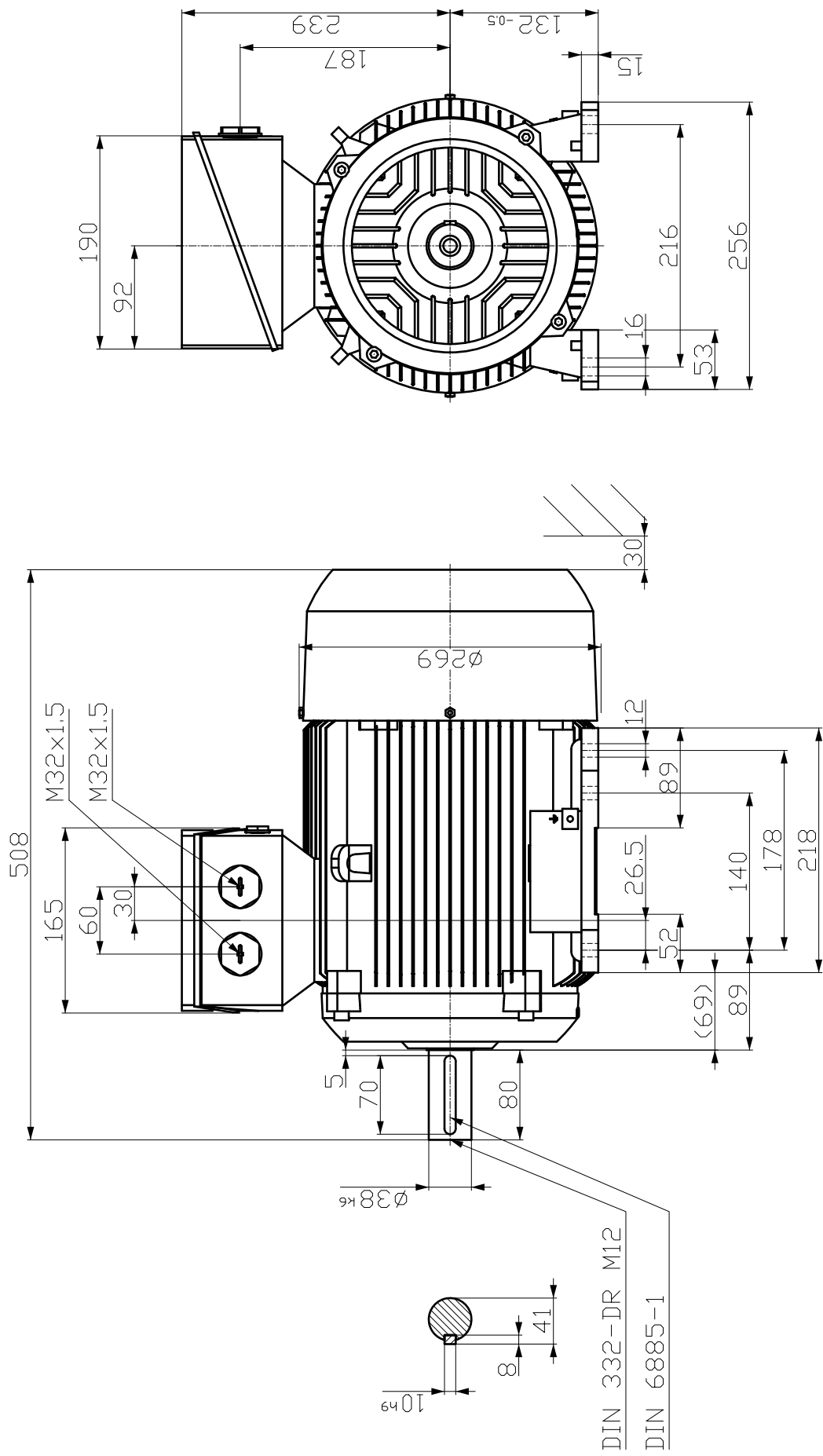

Reference	Surface	Material	Weight	Scale
1LE1603-1CA12-2AB4-Z C02+H07+H22+R50+S03+Y53	Author Creator Approval Department Change Order	Dimensional drawing Maßzeichnung	-	mm
SIEMENS © Siemens AG 2023	Doc. State	Item No	Doc. Type	Paper Size
	Revision	Index	13/04/23	A3
	Project No	Ref. No	IS	1st Language
	6	-	1	en
5	6	7	8	1 of 1

Technische Änderungen vorbehalten!
Technical data are subject to change!

Conținutul este de secret de afaceri. Toate drepturile rezervate.
 Contido como secreto de empresa. Nos reservamos todos los derechos.
 Bona parte copriatorilor sa năm.
 All rights reserved. Reservations are made.
 Bona parte copriatorilor sa năm.
 Soient nicht ausdrücklich gestattet. Zuwahlungen verpflichten zu
 Schadenersatz. Alle Rechte für den Fall der Patentierung, Gebrauch-
 muster- oder Geschmacksmustererhaltung vorbehalten.
 Transmittal, reproduction, dissemination and/or editing of this document as
 well as utilization of its contents and communication thereof to others
 without express authorization are prohibited. Offenders will be held liable
 for payment of damages. All rights created by patent grant or registra-
 tion of a utility model or design patent are reserved.