



Manufacturer

Customer

**VEM motors GmbH - Werk Wernigerode**  
**Carl-Friedrich-Gauß-Straße 1**

**38855 WERNIGERODE**  
**Deutschland**

**Three-phase motors with squirrel cage rotor,**  
**Housing grey cast iron**

Type	IE3-W43R 160 M4 TPM HW		
Design output	( kW )	11	
Design torque	( Nm )	72	
Class IE	[ - ]	IE3-91,4%	
Efficiency determination		EN 60034-2-1	
Duty type		S1	
Design frequency	( Hz )	50	
Design speed	[rpm]	1465	
Voltage	( V )	230/400	
Connection	[ - ]	D	Y
Current	[ A ]	36.5	21.0
Relative pull-in current	[ - ]	7	
Relative starting torque	[ - ]	2,3	
Relative pull-up torque	[ - ]	1,8	
Relative pull-out torque	[ - ]	3,4	
Efficiency100/75/50 %	[ % ]		91,4 / 91,9 / 91,5
Power factor	[ - ]	0,82	
Th. cl.		155(F/B)	
Coolant temperature	( °C )	-20°C...+40°C	
Altitude above sea level	( m )	1000m	
Degree of protection IP		IP55	
Moment of inertia	( kgm <sup>2</sup> )	0,043	
Motor weight	( kg )	105	
Bearing, D-side		6309 ZZ C3	
Bearing, N-side		6308 ZZ C3	
Relubrication interval	( h )		
Grease type		ASONIC GHY 72	
Grease amount	[cm <sup>3</sup> ]		
A-sound pressure level	( dB )	57	

**Options**

Type of mounting	IM B3
Flange	-
Terminal box	Standard
Position of terminal box	on the top
Cable gland	Sealing plug
Position of cable entry	right
Shaft	Standard, 1 shaft end
Bearing	Easy bearing arrangement
Special details to bearings	Fixed bearing, N-side
Winding protection	1 set ptc resistors
Limit values to vibration velocity	Class A
Colour system	Balancing with half key
Delivery conditions and/or official regulations:	01 Moderate (KK C2),RAL 7031 blue-grey IEC / EN 60034-1

This document was produced electronically, all specifications are valid only after confirmation of the manufacturer

Three-phase motors with squirrel cage rotor,  
Housing grey cast iron

## IE3-W43R 160 M4 TPM HW

### Mounting position

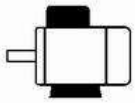

Type of mounting: IM B3  
Flange: -  
Position of terminal box: on the top  
Brake type:  
Forced-ventilation:

Terminal box: KK 63 A  
Cable gland O: 1 x Sealing plug

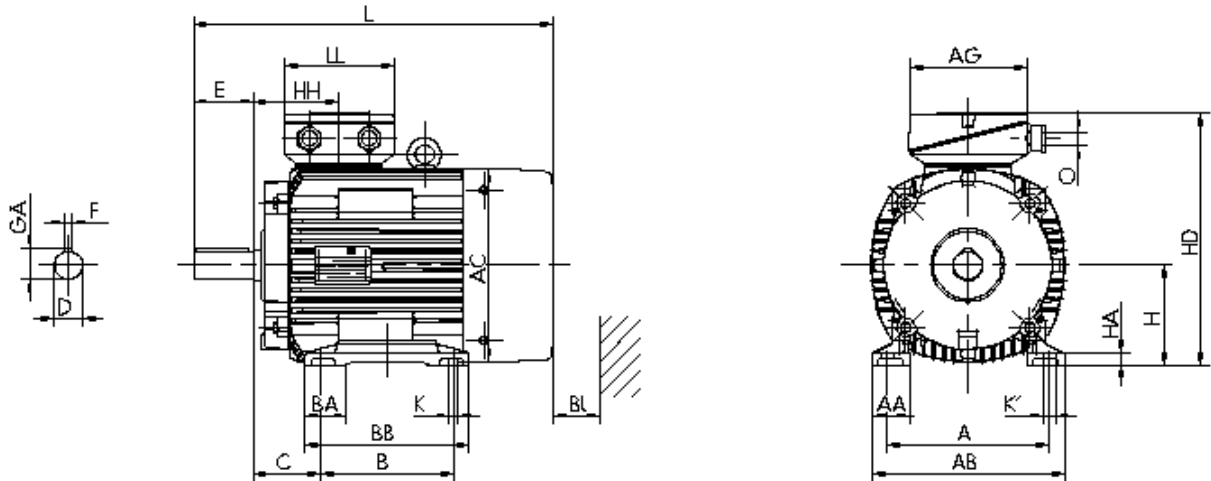

### Motor

A	AA	AB	AC	AD	B	B'	BA	BA'	BB	C	CA	K	K'		
254	55	296	258	-	210		60	-	257	108	-	15	15		
												<b>Protection cover</b>		<b>Terminal box</b>	
L	LC	H	HA	HD	HH	BI	L	AG	LL	BE	AH	-	-		
609	-	160	18	374	114	40	-	193	167	-	-	-	-		

### Flange

P	N	LA	M	T	S	<b>Tolerances</b>							
-	-	-	-	-	-	H	N	D	DA				
						-0,5	h6	k6	k6				

### Shaft-DS

D	E	GA	F	DB
42	110	45	12	DIN 332 DS- M16

### Shaft-NS

DA	EA	GC	FA
-	-	-	-

### DB...Centre hole

Delivery conditions and/or official regulations: IEC / EN 60034-1

This document was produced electronically, all specifications are valid only after confirmation of the manufacturer